



Global Finishing Solutions



ALL SELECT SPRAY BOOTHS FEATURE:

- › Galvanized steel single-skin panel design
 - Smooth interior fit and finish
 - High-strength construction
 - All panels are pre-punched for easy and strong nut and bolt assembly
- › Shadow-free lighting with energy-efficient ETL-listed light fixtures
 - Four color-corrected T-8 fluorescent tubes per fixture
 - Fixtures are inside-accessible with electronic ballasts
- › Energy-efficient fans and motors
 - Heavy-duty construction
 - Fans feature easily adjustable variable-pitch pulleys
- › Vertical or Horizontal air heater placement
- › Easy assembly
- › Full code compliance

White pre-coated panels are optional

SELECT Spray Booths

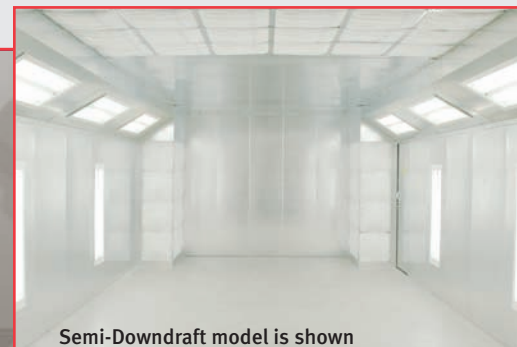

Semi-Downdraft model is shown

AFFORDABLE AND VERSATILE SPRAY BOOTH SOLUTIONS

Global Finishing Solutions Select spray booths surpass all others in their class. Body shops looking for a quality, user-friendly, and affordable spray booth should look no further than the Select spray booth models. Available in all popular airflow types and with multiple options, the Select line offers unequalled value and quality.

DOWNDRAFT

High-performance airflow design

*Floor exhaust pit required

Downdraft airflow provides the optimum airflow for overspray removal. Air is drawn through the ceiling filters, over the vehicle, and is exhausted through a pit in the floor. All overspray is safely contained in the pit filters.

DOWNDRAFT SPECIFICATIONS

Construction:

- Downdraft airflow during spray and cure cycles
- Single-row exhaust pit (21'4" long)
- G-90 galvanized steel

Doors:

- 10' w x 9' h 2-wing entrance door (10' w x 8'10" h opening)
- 1 Personnel access door

Lighting:

- ETL-Listed inside-accessible light fixtures 120/277v
- (10) 4-tube light fixtures
- Energy-efficient electronic ballasts
- T-8 Color-corrected fluorescent tubes

Exhaust System:

- (1) 34" Tube-axial Fan
- (1) 5hp EPACK Motor
- 12,600 CFM @ 3/4" SP
- Booth pressure manometer gauge

Filtration:

- High-efficiency, high-temperature compatible ceiling filter media
- High holding capacity filter media in pit

White pre-coated panels are optional

Dimensions - NON-PRESSURIZED

	Length	Width	Height
Cabin Internal	26'	14'	9'
Cabin External	26'4"	14'4"	9'2"
2-Wing Frontal		10'	9'

Dimensions - PRESSURIZED

	Length	Width	Height
Cabin Internal	26'	14'	9'
Cabin External	26'4"	14'4"	11'4"
2-Wing Frontal		10'	9'

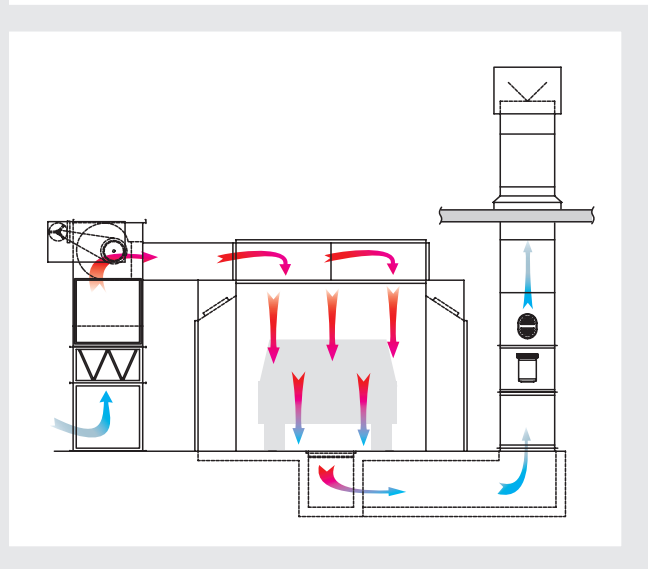

NON-HEATED	Solid Back		Drive-Thru	
	Pressurized	Non-Pressurized	Pressurized	Non-Pressurized
	SLDD-26PSB	SLDD-26NSB	SLDD-26PDT	SLDD-26NDT

HEATED with Control Panel	Solid Back		Drive-Thru	
	Vertical Heater	Horizontal Heater	Vertical Heater	Horizontal Heater
Standard with VFD	SLDD-26PSB-VS-CP	SLDD-26PSB-HS-CP	SLDD-26PDT-VS-CP	SLDD-26PDT-HS-CP
Forced Dry with Dual VFD	SLDD-26PSB-VF-CP	SLDD-26PSB-HF-CP	SLDD-26PDT-VF-CP	SLDD-26PDT-HF-CP
Recirculating 90/10 Cure Cycle with VFD	SLDD-26PSB-VR-CP	SLDD-26PSB-HR-CP	SLDD-26PDT-VR-CP	SLDD-26PDT-HR-CP

Dimensions - NON-PRESSURIZED

	Length	Width	Height
Cabin Internal	26'	14'	9'
Cabin External	26'4"	16'8"	9'2"
2-Wing Frontal		10'	9'

Dimensions - PRESSURIZED

	Length	Width	Height
Cabin Internal	26'	14'	9'
Cabin External	26'4"	16'8"	11'4"
2-Wing Frontal		10'	9'

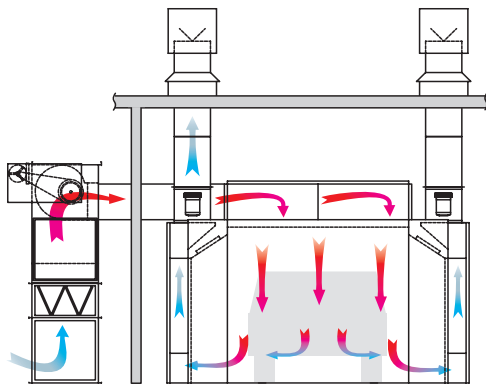

SIDE-DOWN DRAFT

Downdraft airflow with no pit required

The ideal solution for shops where digging a pit is not an option. Side-Downdraft booths provide excellent overspray removal in an innovative design. Air is drawn through the ceiling, over the vehicle, and is exhausted through exhaust chambers on either side of the booth.

SIDE-DOWN DRAFT SPECIFICATIONS

Construction:

- Side-Downdraft airflow during spray and cure cycles
- No pit excavation required
- G-90 galvanized steel

Doors:

- 10' w x 9' h 2-wing entrance door (10' w x 8'10" h opening)
- 1 Personnel access door

Lighting:

- ETL-Listed inside-accessible light fixtures 120/277v
- (10) 4-tube light fixtures
- Energy-efficient electronic ballasts
- T-8 Color-corrected fluorescent tubes

Exhaust System:

- (2) 24" Tube-axial Fans
- (2) 2hp EPACT Motors
- 12,600 CFM @ 3/4" SP
- Booth pressure manometer gauge

Filtration:

- High-efficiency, high-temperature compatible ceiling filter media
- High holding capacity filter media in exhaust chambers

White pre-coated panels are optional

NON-HEATED	Solid Back		Drive-Thru	
	Pressurized	Non-Pressurized	Pressurized	Non-Pressurized
	SLSD-26PSB	SLSD-26NSB	SLSD-26PDT	SLSD-26NDT

HEATED with Control Panel	Solid Back		Drive-Thru	
	Vertical Heater	Horizontal Heater	Vertical Heater	Horizontal Heater
Standard with VFD	SLSD-26PSB-VS-CP2	SLSD-26PSB-HS-CP2	SLSD-26PDT-VS-CP3	SLSD-26PDT-HS-CP3
Forced Dry with Dual VFD	SLSD-26PSB-VF-CP2	SLSD-26PSB-HF-CP2	SLSD-26PDT-VF-CP3	SLSD-26PDT-HF-CP3

SEMI-DOWNDRAFT

Proven airflow design in an economical package

Semi-Downdraft booths fit a variety of unique shop layouts where pits for downdraft booths just aren't feasible. Air is drawn through the ceiling, over the vehicle, and is exhausted through an exhaust chamber at the rear of the booth.

SEMI-DOWNDRAFT SPECIFICATIONS

Construction:

- Semi-Downdraft airflow during spray and cure cycles
- No pit excavation required
- G-90 galvanized steel

Doors:

- 10' w x 9' h 2-wing entrance door (10' w x 8'10" h opening)
- 1 Personnel access door

Lighting:

- ETL-Listed inside-accessible light fixtures 120/277v
- (10) 4-tube light fixtures
- Energy-efficient electronic ballasts
- T-8 Color-corrected fluorescent tubes

Exhaust System:

- (1) 34" Tube-axial Fan
- (1) 3hp EPACT Motor
- 10,500 CFM @ 3/8" SP
- Booth pressure manometer gauge

Filtration:

- High-efficiency, high-temperature compatible ceiling filter media
- High holding capacity filter media in exhaust chamber

White pre-coated panels are optional

Dimensions - NON-PRESSURIZED

	Length	Width	Height
Cabin Internal	26'	14'	9'
Cabin External	26'4"	14'4"	10'2"
2-Wing Frontal		10'	9'

Dimensions - PRESSURIZED

	Length	Width	Height
Cabin Internal	26'	14'	9'
Cabin External	26'4"	14'4"	11'4"
2-Wing Frontal		10'	9'

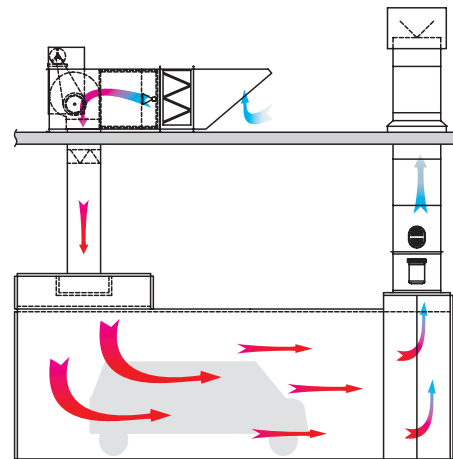

NON-HEATED	Solid Back		Drive-Thru	
	Pressurized	Non-Pressurized	Pressurized	Non-Pressurized
	SLSM-26PSB	SLSM-26NSB	SLSM-26PDT	SLSM-26NDT

HEATED with Control Panel	Solid Back		Drive-Thru	
	Vertical Heater	Horizontal Heater	Vertical Heater	Horizontal Heater
Standard with VFD	SLSM-26PSB-VS-CP	SLSM-26PSB-HS-CP	SLSM-26PDT-VS-CP	SLSM-26PDT-HS-CP
Forced Dry with Dual VFD	SLSM-26PSB-VF-CP	SLSM-26PSB-HF-CP	SLSM-26PDT-VF-CP	SLSM-26PDT-HF-CP
Recirculating 90/10 Cure Cycle with VFD	N/A	SLSM-26PSB-HR-CP	N/A	SLSM-26PDT-HR-CP

Dimensions - NON-PRESSURIZED

	Length	Width	Height
Cabin Internal	26'	14'	9'
Cabin External	26'4"	14'4"	10'2"
2-Wing Frontal		10'	9'

Dimensions - PRESSURIZED

	Length	Width	Height
Cabin Internal	26'	14'	9'
Cabin External	26'4"	14'4"	10'2"
2-Wing Frontal		10'	9'

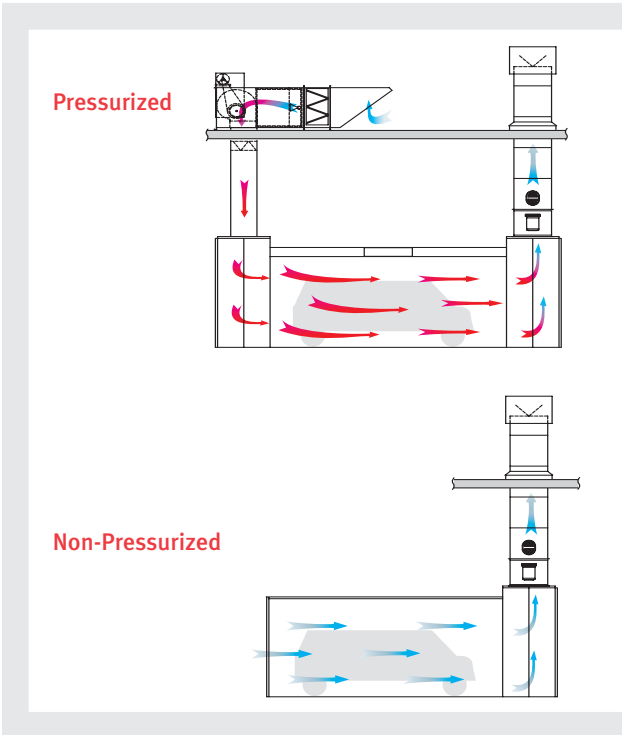

CROSSDRAFT

Classic spray booth design

Crossdraft booths are popular throughout the world. Simple, reliable, and extremely economical, Crossdraft booths fit any type of operation, large or small. Air is drawn through the front of the booth, over the vehicle, and is exhausted through an exhaust chamber at the rear of the booth.

CROSSDRAFT SPECIFICATIONS

Construction:

- Crossdraft airflow during spray and cure cycles
- No pit excavation required
- G-90 galvanized steel

Doors:

- 10' w x 9' h 2-wing entrance door (10' w x 8'10" h opening)
- 1 Personnel access door

Lighting:

- ETL-Listed inside-accessible light fixtures 120/277v
- (10) 4-tube light fixtures
- Energy-efficient electronic ballasts
- T-8 Color-corrected fluorescent tubes

Exhaust System:

- (1) 34" Tube-axial Fan
- (1) 3hp EPACT Motor
- 10,500 CFM @ 3/8" SP
- Booth pressure manometer gauge

Filtration:

- High-efficiency door filter media
- High holding capacity filter media in exhaust chamber

White pre-coated panels are optional

NON-HEATED	Solid Back		Drive-Thru	
	Pressurized	Non-Pressurized	Pressurized	Non-Pressurized
	SLCD-26PSB	SLCD-26NSB	SLCD-26PDT	SLCD-26NDT

HEATED with Control Panel	Solid Back		Drive-Thru	
	Vertical Heater	Horizontal Heater	Vertical Heater	Horizontal Heater
Standard with VFD	SLCD-26PSB-VS-CP	SLCD-26PSB-HS-CP	SLCD-26PDT-VS-CP	SLCD-26PDT-HS-CP
Forced Dry with Dual VFD	SLCD-26PSB-VF-CP	SLCD-26PSB-HF-CP	SLCD-26PDT-VF-CP	SLCD-26PDT-HF-CP

CONTROL PANELS

PLC Equipped and UL listed

Standard Remote (Model SP) has a 2-line digital text display, that displays operations and faults. Touch pad has function buttons for operator control. Pressure gauge indicates booth pressure. Manual balance control.

MasterCure Remote (Optional/Upgrade) has a touch-panel interface function. Multiple screens for operator control and viewing of operation status and faults. Auto-balance control. SmartCure option has 7 selectable profiles; 4 presets and 3 user defined (recirculating systems only).

Remote operators come with a 45' cable for simple connection to the air handler. Cable is color coded for easy connection to terminal strip. All heated booths are equipped with state-of-the-art PLC controls for precise control of operation and temperature.



Standard Remote



MasterCure Remote

AIR HEATER

Standard Features

- › Versatility
 - available as vertical or horizontal mount
 - unit will deliver 12,600 CFM
- › Temperature rise up to 100° F - Standard Heater
- › Energy efficient Forced Dry or Recirculating heaters are available
- › ANSI standard gas train sized for 7"-14" natural gas pressure
- › Comes equipped with a 10 HP 3-phase motor
- › ETL listed (when ordered with controls)
- › G-90 galvanized enclosure
- › Ready for indoor/outdoor use (with optional outdoor kit)
- › Equipped with an enclosed stand for vertical configuration – air intake from any side
- › Horizontal units are equipped with an intake hood and filter
- › Interior lined for rigidity and future high-temp application
- › Motor is mounted out of the airstream for easy access
- › Discharge:
 - Vertical units - top or side
 - Horizontal units - end or bottom
- › All paint booth controls mounted in air replacement control section
- › Main disconnect
- › Standard voltages: 208 / 230 / 480 Volt, 3-phase
- › Pre-wired remote PLC control panel with digital display
- › Exhaust unit VFD
- › Booth air flow balance control

AIR HEATER OPTIONS:

- › Single-phase motors
- › Auto-Balance (pressure)
- › Recirculating Cure mode
- › Touch-screen PLC remote control panel
- › Propane fuel burner
- › Intake baffle and diffuser



AIR HEATER Placement Options

Select Air Heaters are designed for vertical or horizontal placement. Heaters are available in three models:

- > Standard Heater with VFD
- > Forced-Dry Curing Heater with Dual VFD
- > Recirculating (90/10) Curing Heater with VFD

ALL HEATED BOOTHS INCLUDE SINGLE OR DUAL VFDS FOR BETTER PERFORMANCE AND ENERGY SAVINGS.

Outdoor Vertical

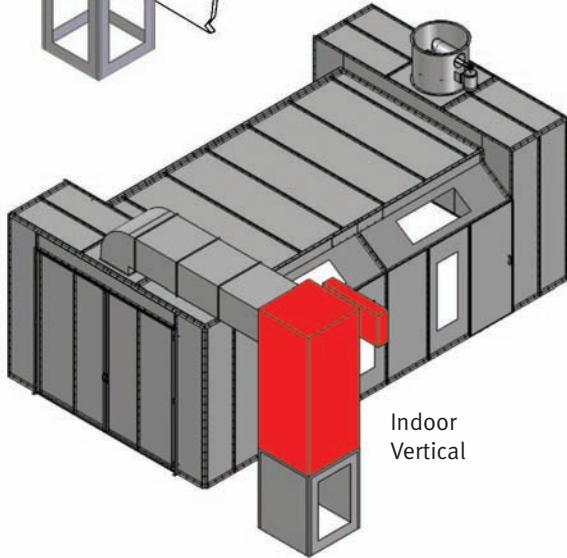
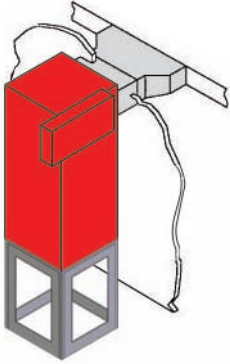

Indoor Vertical

Outdoor Horizontal

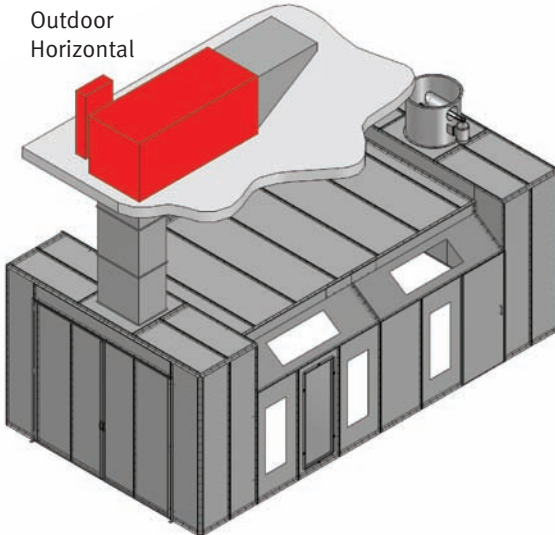

Indoor Horizontal with support cradle

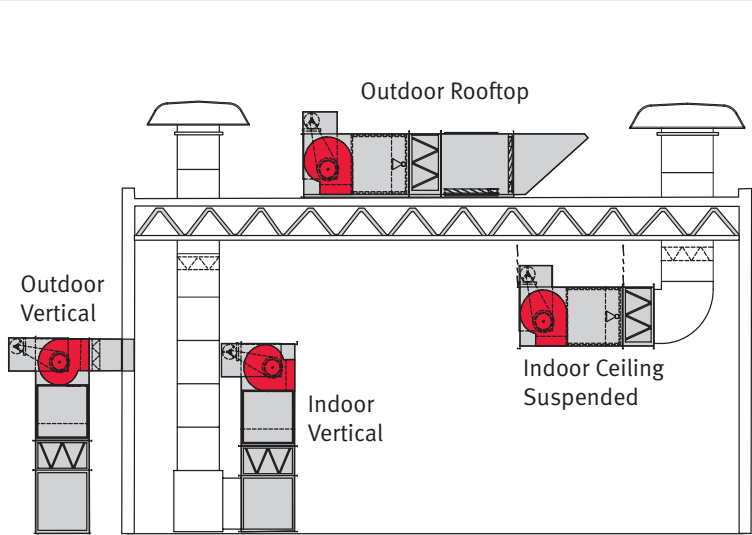
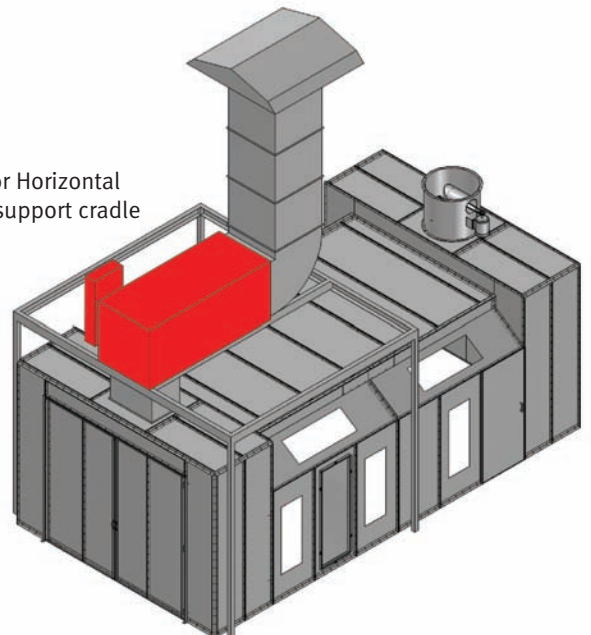

This illustration is for example purposes only

RECIRCULATING BOOTHS - MAXIMUM ENERGY SAVINGS!

Dampers reduce exhaust to approximately 10%, delivering approximately 90% of the previous heated air and 10% fresh air into cabin during cure cycle.

Recirculating Cure (90/10) is available for Downdraft and Semi-Downdraft models ONLY.

ACCESSORIES

INDUSTRIAL GRADE EXHAUST FAN ASSEMBLY

Units are pre-assembled at the factory and include variable-pitch motor sheaves for maximum operating efficiency and on-site adjustment. Motors are mounted away from of the airstream for easy access.

- › Cast aluminum fan blades and hub
- › Continuously-welded heavy-duty steel housing assures no air leaks



LIGHTS

GFS lights are 4-foot, 4-tube, Class 1 Division 2, E.T.L. listed (report# 3080616-H01) fluorescent light fixtures. Inside access fixtures with interlock switch are standard features.

- › T-8 high efficiency color-corrected tubes
- › 120/277 volt, 50/60Hz lighting



OPTIONS AVAILABLE ON ALL SELECT SPRAY BOOTHS:

- › Drive-Thru Configurations
 - Easier movement of vehicles through the booth
 - Improve workflow in your shop
- › Observation windows
- › Control packages
- › White coated panels
- › Ductwork packages
- › Single phase motors

EXHAUST STACK KITS:

Exhaust Stack Kits include: (3) 3ft-Plain Exhaust Duct sections, (1) 3ft-Universal Stack with Access Door, and (1) Roof Ventilator

WITH ROOF FLANGE

DU-STK-24-WF
DU-STK-34-WF

WITHOUT ROOF FLANGE

DU-STK-24 24"
DU-STK-34 34"

The following diagrams illustrate how the different components are used to make up the several systems.

Outlet in Roof

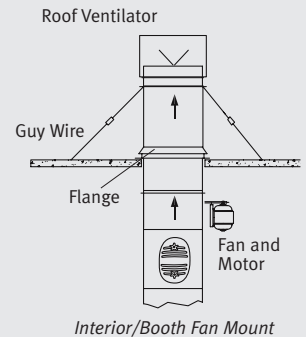
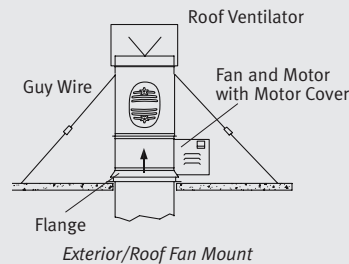

Outlet in Wall

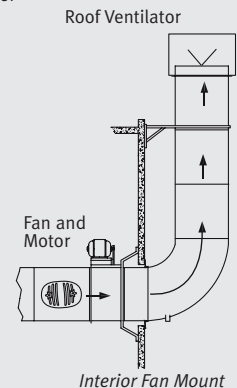
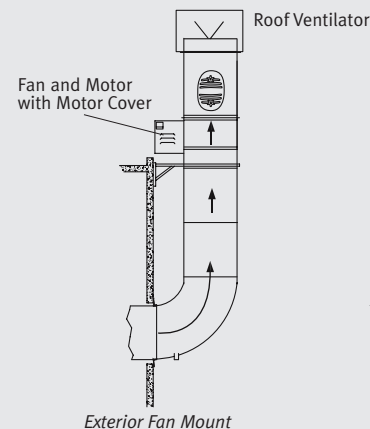

For unusual applications consult GFS for recommendations. (Plain duct section overall length - 36", assembled length - 34").

Note: Check with your local area inspector for code compliance.



Consult your Global Finishing Solutions sales representative for details of required installation, electrical wiring, conduit, air piping, roof penetrations, and automatic fire suppression. The equipment installation location should be reviewed and approved by the local authorities having jurisdiction. Global Finishing Solutions recommends proper facility air replacement with exhaust equipment.

Dallas, TX • Barrie, ON • Osseo, WI • Mexico

800-468-5879 • www.globalfinishing.com • e-mail: auto@globalfinishing.com